



Impact Assessment of Elevation Angles on Signal Propagation at VHF and UHF Frequencies for Improved Rural Telephony

Ubong UKOMMI¹, Emmanuel UBOM¹

¹Department of Electrical and Electronic Engineering, Akwa Ibom State University, Ikot Akpaden, Nigeria
ubongukommi@aksu.edu.ng / emmanuelubom@aksu.edu.ng

Corresponding Author: ubongukommi@aksu.edu.ng, +2347032465163

Date Submitted: 01/08/2022

Date Accepted: 05/01/2023

Date Published: 20/11/2023

Abstract: Rural telephony is challenging in the remote part of Nigeria due to inadequate telecommunication infrastructure, exorbitant cost of communication systems and poor road network for extension of fiber network. These factors constitute poor or no cellular network services in many villages. Alternatively, using Television White Space (TVWS) technology to facilitate telephony services in the rural areas through Ultra High Frequency (UHF) and Very High Frequency (VHF) spectrum is cost effective. Thus, this research investigates impact of elevation angle on signal propagation at UHF/VHF frequencies. The experimental test scenarios took measurements of received signal quality performance at different elevation angles and transmit power levels to obtain more stable results for substantive inference. The experimental test scenario considered a communication link, operating at UHF frequency of 436 MHz. During the experiment, azimuth and propagation loss for the communication link were kept constant while the receiving antenna elevation angles were varied to assess the impact of elevation angles. The assessment examined results obtained during the experiment. Comparing the received signal quality performance at zero (0°) elevation angle, it has been observed that the received signal quality improves when the transmit power allocation increases. Results further show that for a given transmit power level of 34dBm, at zero (0°) elevation angle test configuration, received signal quality performance of 1.80 dB, 6.90 dB at 30° elevation angle and 10.9 dB at 60° elevation angle were obtained, compared to improved quality performance of 11.8 dB at 0° elevation angle, 19.90 dB at 30° elevation angle and 24.92 dB at 60° elevation angle when the transmit power level was increased to 46.98 dBm. It is deduced from the experimental results that elevation angle of receiving antenna has significant influence on the received signal quality performance. This insight is very useful in the design and network planning of rural telecommunication services using TVWS frequencies for improved rural broadband penetration.

Keywords: Antenna, Elevation Angle, Ultra High Frequency (UHF), Telecommunication and Very High Frequency (VHF).

1. INTRODUCTION

Provision of digital communication services to rural dwellers is difficult due to several factors including, characteristic of the rural areas with obstacles such as rough terrain, forest and buildings blocking the Light of Sight. Unfortunately, extension of Third Generation (3G), Fourth Generation (4G) and Fifth Generation (5G) [1] mobile broadband services to rural areas is not commercially viable for the telecommunications operators due to high cost of setting up mobile base stations, low population in the rural areas and low patronage from rural dwellers. Alternatively, Television White Space (TVWS) [2-3] can be harnessed for improved wireless communication in the remote areas using Very High Frequency (VHF) and Ultra High Frequency (UHF) spectrum propagation. Based on the International Telecommunications Union (ITU) and Institution of Electrical and Electronic Engineers (IEEE), VHF band is classified as 30 MHz – 300 MHz and UHF in the range of 0.3 GHz - 3.0 GHz frequency spectrum. The propagation characteristics of wireless signals in the television bands can cover a wider area compared to those at higher frequencies. TVWS technology harnesses the unused television broadcasting spectrum in the UHF band on a secondary basis without destructive interference to the primary television receivers [4]. It is very useful in developing countries like Nigeria with large part of unoccupied UHF channels. TVWS is free for secondary use making it cost effective solution for broadband access in the rural areas. TVWS in low-band UHF frequencies exhibits propagation characteristics of long range and the ability to penetrate obstacles such as heavy tree foliage and buildings [5-6]. Various modes of signal propagation include ground-wave propagation, sky-wave propagation and Line-of-Sight (LOS) propagation widely deployed in VHF and UHF Amateur satellite communications. LOS propagation requires a path where both antennas are visible to one another and there are no obstructions. Radio communication range is significantly affected by variable propagation conditions including frequency of propagation; transmit power level, system configuration, atmospheric effects, rain and terrain. The angle of radiation of a signal from an antenna is one of the key factors determining effective communication distances. UHF antenna is usually mounted on high buildings for optimum reception.

However, communications at higher frequency are generally challenging because of high power needed and equipment cost. Various modes of propagation of electromagnetic signals from transmitting antenna to the receiving antenna include

ground-wave propagation, sky-wave propagation and Line-of-Sight (LOS) propagation widely deployed in VHF and UHF communications. There are various techniques of improving signal quality; including integration of good low noise amplifier and increment of transmit power level [7-8]. However, arbitrarily increment of transmit power level could results in interference which are often unrideable by telecommunication operations. Thus, the need for investigation and development of an alternative approach to improve signal quality performance. The objective of this research includes assessment of impact of elevation angle of signal propagation at UHF/VHF radio spectrum bands. The insight gained from the research can be useful for development of telephony applications in the rural areas where there is limited or no functional 3G or 4G mobile telecommunication networks. Section two describes materials and methodology deployed during the research. Section 3 presents results and discussion of experiments. Section 4 presents the conclusion.

2. MATERIALS AND METHOD

The experiment was carried out to investigate the relationship of elevation angle of propagation and received signal performance in UHF and VHF spectrum. The experiment carried out in a ground station laboratory with transmit and receive facilities consist of yagi uda antenna, digital compass, spectrum analyser, attenuator (3 dB, 10 dB and 20 dB), termination 50 Ω, Dummy load 50 Ω, reference coaxial cable port connector, ICOM IC 910 H transceiver, rotator and controller for angle of elevation configuration. A workstation was also connected to the system for monitoring and control of the experiment. The controller and microcontroller were deployed in configuration of different test angles of elevation for experimental purpose. The experiment was performed such that the signal strengths and elevation angles of propagation were recorded for analysis at different test scenarios. Then the signal strength at the receiving section was also measured. This procedure was repeated for different elevation angle of propagation while taking note of the received measured signal quality values. The transmit power levels, elevation angles of signal propagation (at zero degree, 0°, 30° and 60°) and the corresponding received signal quality values were logged and recorded for analysis. The system architecture is presented in Figure 1.

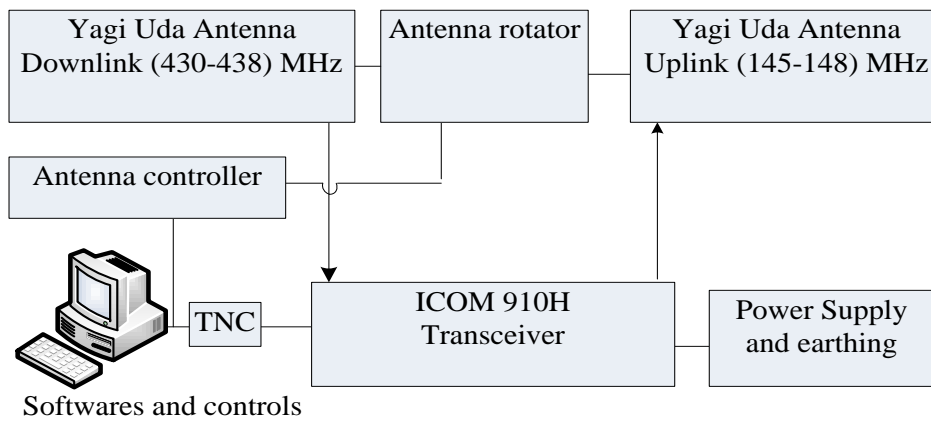

Figure 1: System configuration



Figure 2: Transceiver sensitivity test

Figure 1, presents the system architecture, consisting of Yagi Uda antenna, transceiver with a receiving sensitivity level of -126dBm, earthing system, power module, Terminal Node Controller (TNC), Low Noise Block down converter (LNB), antenna controller, electric rotor for elevation angle adjustment. The computer system and software perform tracking, controls, configuration of the transceiver and digital signal processing. A set of two Yagi Uda antennas [9] with a gain of 15.0 dB are used for the experimental set up. The antennas serve as medium for propagation and reception of electromagnetic signals. The transceiver was configured with the Terminal Node Controller (TNC) for synchronization and demodulation of signals in UHF frequency spectrum and modulation of signals during transmission operation at the VHF frequency spectrum. Figure 2, presents system configuration for the transceiver's sensitivity test. The transceiver sensitivity level test result shows that at signal level of -136d Bm the transceiver could not detect the signal until the signal strength was increased to -126 dBm.

2.1 Design and Link Analysis

The design and link analysis were performed to establish a communication link between a satellite and experimental ground station operating at UHF/VHF for proper investigation of the impact of elevation angle of propagation on UHF and VHF frequencies spectrum. A detailed communication link analysis was investigated to assess the impact of elevation angles on received signal quality. In this research work, signal quality between a ground station and satellite was considered. Signal radiation from antenna creates an electromagnetic wave that spreads outward from the antenna through space. Factors such as frequency of operation, transmit power, equipment configuration, atmospheric effects, rain and terrain are considered in the link budget analysis for the experimental set up. The experimental configuration measures received signal performance at various elevation angles of the receiving antenna. In the link analysis, free space loss between the reference satellite at a distance of 3300 km, with a downlink frequency of 435.300 MHz was considered, using Friss transmission model [10-14] such that if the power input to transmitting antenna is P_t , then the power density (S) incident on receiving antenna is given by:

$$S = \frac{P_t G_t}{4\pi r^2} \tag{1}$$

Where, G_t is the maximum gain of the transmitting antenna expressed by:

$$G_t = \frac{4\pi}{\lambda^2} \times A_e \tag{2}$$

The received power at the ground station is given by:

$$P_r = \frac{P_t G_t}{4\pi r^2} A_{er} \tag{3}$$

Where r the maximum range between the satellite and ground station, $P_t G_t$ is the Effective Isotropic Radiation Power and A_{er} is the effective area of the antenna. Substituting G_t and G_r in Equation (3):

$$\frac{P_r}{P_t} = G_t G_r \left(\frac{\lambda}{4\pi r} \right)^2 \tag{4}$$

Re-arranging Equation (4) in line with Free Space Loss (FSL) [15-17]:

$$FSL = \frac{P_t G_t G_r}{P_r} = \left(\frac{4\pi r}{\lambda} \right)^2 \tag{5}$$

$$FSL_{dB} = 20\log(4\pi) + 20\log(r) - 20\log(\lambda) \tag{6}$$

Where, $\lambda = \frac{c}{f} = \frac{3 \times 10^8}{435.5 \times 10^6} = 0689m$

Thus, pathloss at the range of 3300km between satellite and receiving experimental set up is given by:

$$FSL_{dB(max)} = 21.98 \text{ dB} + 20\log(3300 \times 10^3) - 20\log(0.689) = 155.58 \text{ dB}.$$

The Effective Satellite Isotropic Radiated Power is given by, $EIRP_s = P_{ts} \times G_{ts} \times L_{ts}$ (7)

Where P_{ts} , G_{ts} and L_{ts} are the satellite transmit power, satellite antenna gain and satellite transmission loss.

Thus, $EIRP_{ts} = 30d \text{ Bm} + 2 \text{ dB} - 1 \text{ dB} = 31 \text{ dBm}$.

Signal level at receiving experimental set up ground station antenna, $SL = EIRP_{ts} - L_{ts} + G_r$, where G_r is the gain (15.00 dB) from the receiving antenna at the ground station and L_{ts} is the total loss (-163.58dBm). Therefore;

$$SL = 31 \text{ dBm} - 163.58 \text{ dBm} + 15.00 \text{ dB} = -117.58 \text{ dBm}.$$

Thus, signal value -117.58 dBm at the experimental receiving ground station is above receiver's sensitivity level of -126 dBm. Table 1, presents link budget for the communication.

Table 1: Link budget for the communication

Parameter	Value	Unit
Spacecraft:		
Power output	1.00	dB
Antenna gain	2.00	dB
Transmission line loss	-1.00	dB
EIRP	2.00	dBW
Receiving VHF/UHF Experimental Setting		
Antenna pointing loss	-1.00	dB
Antenna Polarization loss	-3.00	dB
Path loss (between spacecraft and ground station)	-155.58	dB
Interference loss	-1.00	dB
Atmospheric loss	-1.00	dB
Receive aspect ratio	-1.00	dB
Antenna Gain	15.00	dB _i
Line loss	-1.00	dB
Effective temperature	25.88	dB/K
Receiver Bandwidth	30.00	KHz
Noise Power (KTB)	-160.95	dBW
SNR	15.37	dB
Service Requirement:		
SNR requirements for (10 ⁻⁶ BER)	12.00	dB
Margin	3.37	dB

Table 1, presents satellite, ground station and service requirements parameters. The link margin of 3.37 dB was achieved without considering LNA gain. However, with integration of LNA the margin improved significantly.

3. RESULTS AND DISCUSSIONS

In this section, the experimental results obtained at different test scenarios and varied elevation angles are presented and analysed to draw a useful insight for enhancement of rural telephony using VHF/UHF frequencies spectrum. The objectives of the experiment include impact assessment of received antenna elevation angle for signal quality enhancement. The experimental set up considered different elevation angles of the received antenna, transmit power levels and received signal quality. The result of the experiment carried out at zero degree elevation angles is presented in Figure 3.

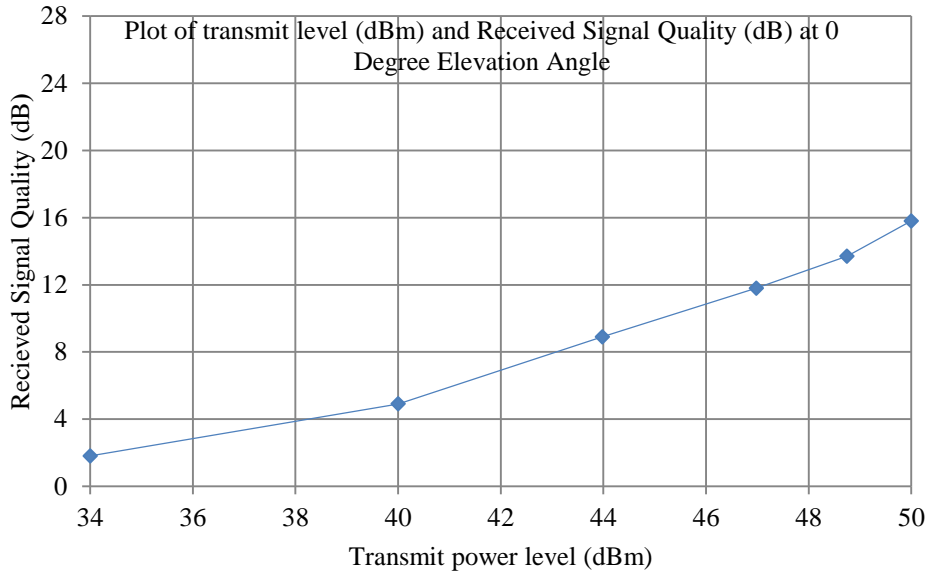

Figure 3: Plot of transmit power level (dBm) and received signal quality at 0 degree elevation angle.

Analysis from Figure 3, shows that the received signal quality improves as the transmit power level increases from 34 dBm to 50 dBm. The received signal quality improves from 1.8 dB at 34 dBm to 15.80 dB at 50 dBm. The improvement in the received signal quality is as a result of increment in the Signal to Noise Ratio (SNR) in terms of transmitting power level. In the second test scenario, the elevation angle of the receiving antenna was reconfigured from zero degree elevation to 30°. The results obtained at elevation angle of 30 degree under different transmit power levels are presented in Figure 4.

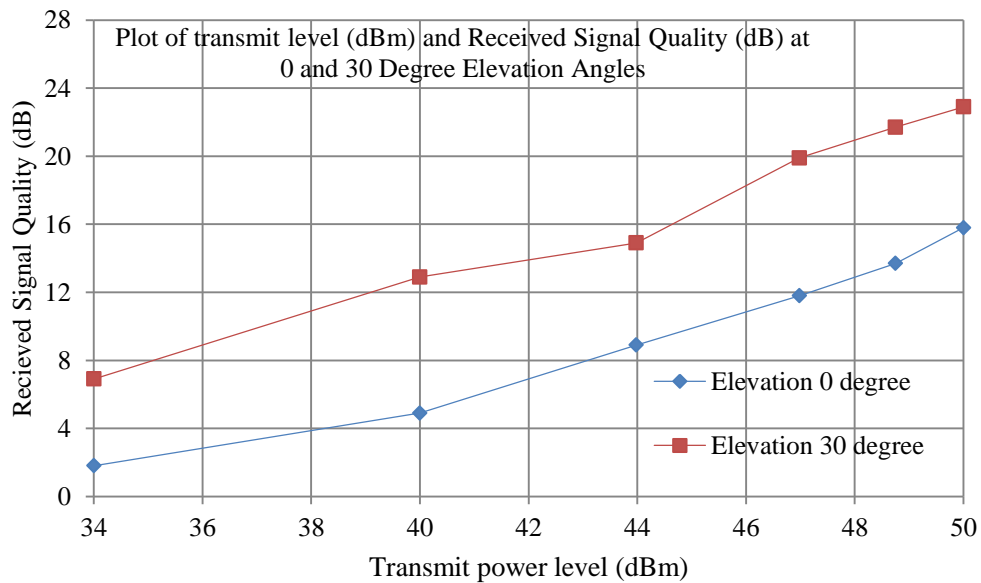

Figure 4: Plot of transmit level (dBm) and received signal quality (dB) at 0 and 30 degree elevation angles.

It can be depicted from Figure 4, that the average received signal quality performance at 30 degree elevation angle shows improvement compared to the received signal quality performance at 0 degree elevation angle. It can be deduced that at the same transmit power level of 40 dBm, the received signal quality performance at 30 degree angle of elevation outperforms that signal quality performance at 0 degree angle of elevation with an average margin of 8.0 dB as presented in Figure 4. This noticeable performance is a result of improvement in the angle of elevation of the received antenna. The third test scenario, where the angle of elevation was further increased from 30 degree to 60 degree was carried out at different transmit power levels to assess the effect on received signal quality. Table 2, presents the received signal quality performance results at different elevation angles and transmit power.

Table 2: Received signal quality performance at different elevation angles.

Power Level (W)	Power Level (dBm)	Received Signal Quality at Different Elevation Angles (dB)		
		0°	30°	60°
2.50	34.00	1.80	6.90	10.90
10.00	40.00	4.90	12.90	15.92
25.00	43.98	8.90	14.92	20.90
50.00	46.98	11.80	19.90	24.92
75.00	48.75	13.70	21.70	25.70
100.00	50.00	15.80	22.90	26.90

Table 2, presents the average received signal quality performance at 0°, 30° and 60° elevation angles for comparative analysis. It has been observed that as the elevation increases, the corresponding received signal quality performance also improves. At the increment of the elevation angle from 30° to 60°, the corresponding received signal quality also improves from 14.90 dB to 20.90 dB, under similar transmit power level of 43.98 dBm as presented in Table 2. Figure 5, presents test results of received signal quality at 60°, 30° and 0° elevation angles at different transmit power levels.

Figure 5, presents a plot of received signal quality (dB) at different elevation angles (0°, 30° and 60°) at different transmit power levels (dBm). It can be observed that at the transmit power level of 34 dBm, the corresponding received signal quality is relatively low, 1.80 dB, at zero degree (0°) elevation angle, while at the same transmit power level of 34 dBm, the corresponding received signal quality improves to 6.90 dB at (30°) and 10.90 dB at (60°) elevation angles, respectively. It could also be observed that at the transmit power level of 40 dBm, the corresponding received signal quality performances are 4.90 dB at zero degrees (0°), 12.90 dB at 30° and 15.92dB at 60°degrees elevation angle. When the transmit power level was further increased further to 43.98 dBm, the corresponding received quality performances for 0°, 30° and 60° are 8.90 dB, 14.92 dB and 20.90 dB, respectively as presented in Figure 5. It has been observed that as the elevation angle increases the received signal quality improves. It has also been observed that as the transmit power level increases the received signal quality performance improves significantly. Thus, the elevation angle of receiving antenna influences the performance of signal propagation at UHF/VHF frequencies spectrum. It is obvious that, increase in elevation angle of the receiving antenna improves the received signal quality in clear sky case as a result of decrease in attenuation of the received signal.

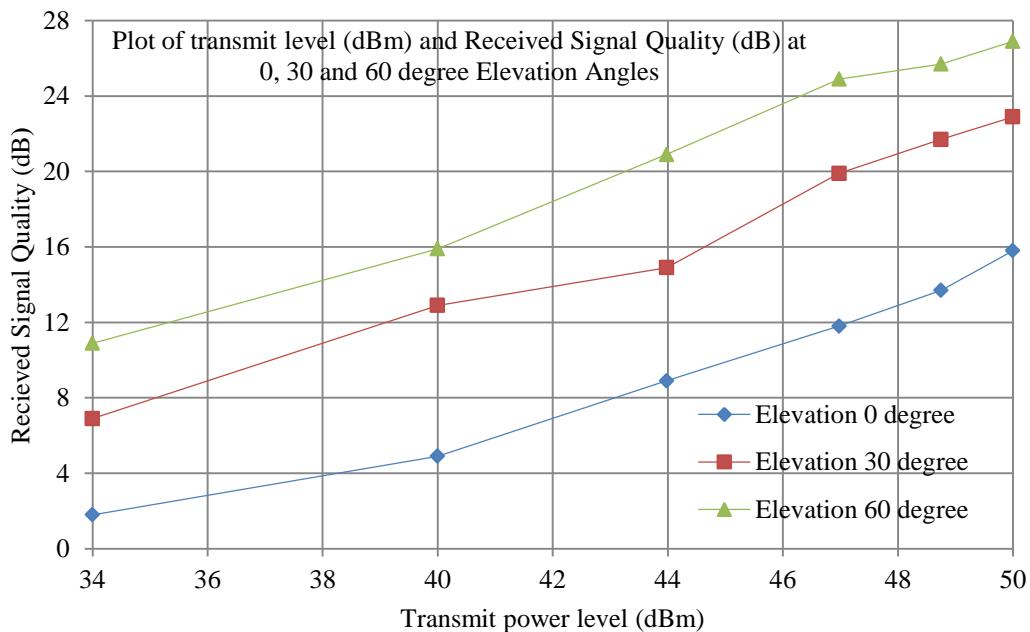

Figure 5: Plot of transmit level (dBm) and received signal quality (dB) at 0, 30 and 60 degree elevation angles.

4. CONCLUSION

In this research paper, assessment of impact of elevation angle [18] on propagation of UHF/VHF signals was investigated. Based on the experimental results conducted using Yagi antenna, it has been observed that the elevation angle

of the received antenna influences the received signal performance at VHF/UHF frequencies spectrum. The results recorded from various propagation test scenarios by varying receiving elevation angles show clearly that the elevation angle of the receiving antenna has significance influence on the receiving signal quality. The fact is revealed from the results obtained at the test elevation angles of 0° , 30° and 60° and the corresponding average received signal quality of 1.8 dB, 6.9 dB and 10.9 dB respectively at fixed azimuth and transmit power level of 34dBm. This knowledge would be useful in the network design and planning concepts for effective rural telecommunication services by harnessing available VHF/UHF frequency spectrum through application of TVWS technology.

REFERENCES

- [1] Osseeiran, A., Parkvall, S., Peterson, P., Zaidi, A., Magnusson, S. & Balachandran (2020). 5G Wireless Access: An Overview. White paper, Ericsson Research, Stockholm.
- [2] Zhang, W., Yang, G., & Yao, C. K. (2018). TV White Space and Its Applications in Future Wireless Networks and Communications: A Survey. *IET Communications Journals*, 12(20), 2521-2532.
- [3] G.Ding, Wang, J., Wu, Q. Yan Y, Song, F. & Tsiftsis, T.A. (2016). Cellular-Based-Station-Assisted Device-to-Device Communication in TV White Space. *IEEE Journal on Selected Areas in Communications*, 34 (1), 107-121.
- [4] Flores, A., Guerra, R., Knightly, E., Ecclestine, P. & Pandley, S. (2015). A Standard for TV White Space Spectrum Sharing. *IEEE Communications Magazine*, 51(10), 92-100.
- [5] Ofcom, (2015). Implementing TV White Space. Retrieved from <https://www.ofcom.org.uk>
- [6] Ubom, E., Akpanobong, A. & Ukommi, U. (2021). Spectrum Occupancy in Rurl Nigeria: A Case for a liightly Licensed Spectrum Band for Rural Broadband Enhancement. *International Journal of Computer and Information technology*, 11(4), 81-99.
- [7] Ukommi, U. (2020). Media Motion-based Resource Distribution for Mobile Video Networking. *Nigerian Journal of Technology (NIJOTECH)*, 39 (4), 1185-1189.
- [8] Ukommi, U., Ubom, E. & Ikpaya, I. (2021). Ground Station Design for Satellite and Space technology Development'. *American Journal of Engineering Research (AJER)*, 10 (8), 12-19.
- [9] International Telecommunication Union. (2016). Systems and Networks for Fixed-Satellite Service, Mobile-Satellite Service, Broadcasting Satellite Service and Radiodetermination-Satellite Service, Radiocommunication Study Group. Retrieved from <https://www.itu.int/en/ITU-R/study-groups>.
- [10] Saunders, S. & Aragon-avala, A. (2007). *Antennas and Propagation for Wireless Communication Systems*, 2nd Ed, John Wiley and Sons Limited, Sussex, England.
- [11] Choi, T., Stevenson, T. & Lightsey, E. (2017). Reference Ground Station Design for University Satellite Missions with Varying Communication Requirements. Georgia Institute of Technology, Atlanta, American Institute of Aeronautics and Astronautics, Texas, United State of America, 1(1), 1-8.
- [12] Ogunjide, S., Ohize, H. & Usman, A. (2020). Suitable Propagation Models for 2.4GHz Wireless Networks; Case Study of Gidan Kwano Campus, FUT Minna, *ABUAD Journal of Engineering Research and Development (AJERD)*, 3(1), 156-165.
- [13] Ukommi, U., Ubom, E. & Abraham, I. (2020). Outdoor 2.4GHz band Wifi Networks Performance Characterisation. *International Journal of Engineering and Technical Research*, 9(8), 207-212.
- [14] Adeniji, K., IKpeze, O., Ejidokum, T. & Alli, K. (2017). Analysis of Propagation Models for Base station Antenna: A case Study of Ado-Ekti, Nigeria. *ABUAD Journal of Engineering Research and Development (AJERD)*, 1(1), 124-129.
- [15] Ekanem, H.H., Ubom, K. E. & Ukommi U. (2022). Analysis of Rain Attenuation for Satellite Communication in Akwa Ibom State, Nigeria. *The Nigerian Institute of Electrical and Electronic Engineers (NIEEE) Proceedings of the International Conference and Exhibition on Power and Telecommunication (ICEPT 2022)*, 23-34.
- [16] Olurope, O., Ukommi U. & Udoh, R. (2022) Comparative Coverage and Horizon Plane Analysis for LEO, MEO, GEO and HEO Satellites. *Journal of Multidisciplinary Engineering Science and Research (JMESR)*, 1(2), 54-56.
- [17] Bazdresch, M., Velayudhan, S. & W. Johnson, (2016). A Satellite Ground Station for Teaching Digital and Wireless Communications, *IEEE Frontiers in Education Conference*, United States of America, 1(1), 1-4
- [18] Udoh, R. & Ukommi, U. (2022). Determination of Visibility Time for Geodesic Satellites Orbiting the Earth on Circular Orbit Subject to Minimum Zenith Angle Restriction. *International Multilingual Journal of Science and Technology (IMJST)*, 7(6), 5435-5443.